

## Single 10/100 BASE-TX Filtered Connector MODEL NO. : TJL-009LA1

### Features :

- ⊙ RoHS Compliant
- ⊙ Do not use material and use that the prohibition that SS-00259 stipulates
- ⊙ Fully shielded magnetics protect data from internally generated digital noise
- ⊙ Reduces the overall length of the signal path for improved common mode performance
- ⊙ Implements full common mode termination scheme with used and unused twisted pairs
- ⊙ Meets IEEE802.3 Baseline Wander Compensation specification
- ⊙ Integrates high voltage capacitor to chassis ground
- ⊙ Supports all major transceivers with matched turns ration and complete integration of specified termination
- ⊙ Design for 100base-tx transmission over UTP-5 cable
- ⊙ Operating TEMP. range: -40°C to +85°C
- ⊙ Storage TEMP. range: -55°C to + 125°C
- ⊙ Primary OCL inductance: 350μH MIN. at 100KHz/0.1Vrms with 8mA DC bias

### Typical Performance Characteristics @25°C

Insertion Loss (dB MAX)	Return Loss (dB Min @100±15Ω)				Differential to Common Mode Rejection (dB MIN)	Cross talk (dB MIN)					CMRR (dB MIN)	Isolation Voltage (Vrms min)
	MHz	MHz	MHz	MHz		MHz	MHz	MHz	MHz	MHz		
1~100	1~30	40	50	60~80	1~100	20	40	60	80	100	1~100	1500
-1.0	-16	-14	-12	-10	-33	-47	-40	-37	-35	-33	-30	

### Schematic Design on MDI Interface Circuitry

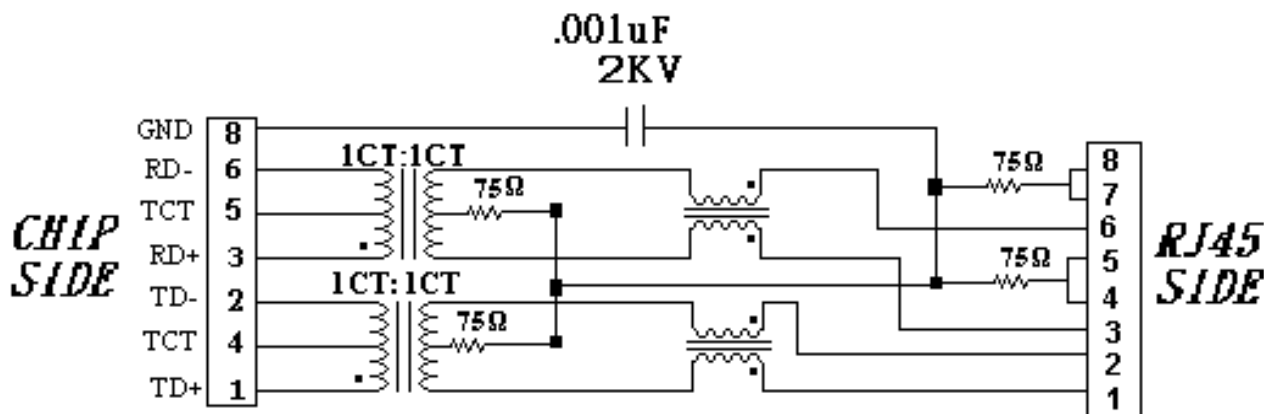

## MODEL NO. : TJL-009LA1

Dimension: mm

TOLERANCE:±0.15 (unless otherwise specified)

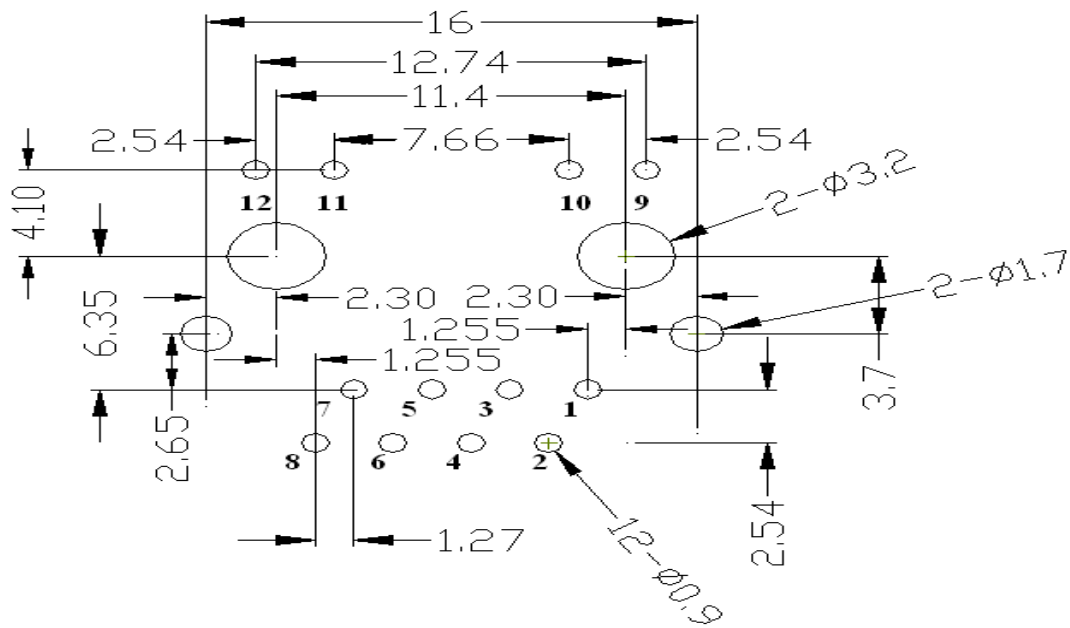
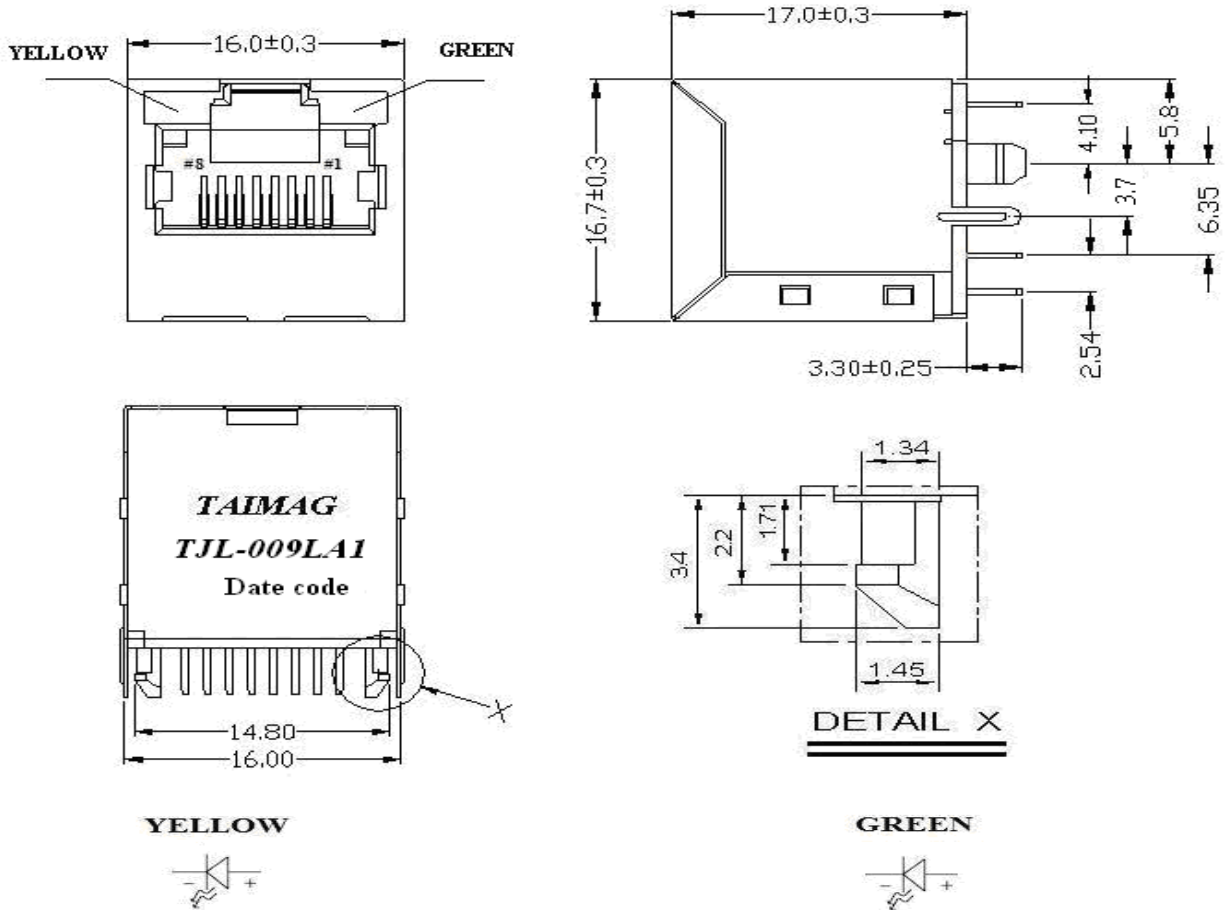

SUGGESTED PCB LAY OUT  
(TOP VIEW)

## MODEL NO. : TJL-009LA1 Ordering Information

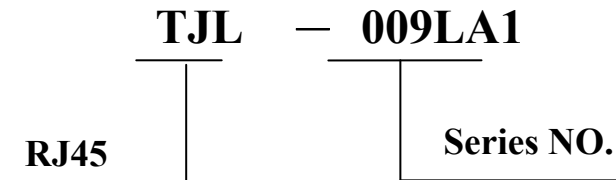

### Requirements :

#### 1. Design and Construction

Product shall be of design, construction and physical dimensions specified on applicable product drawing.

#### 2. Materials and Finish

##### A. Contact:

**RJ Contact : Phosphor Bronze, Thickness=0.30mm**

**Finish :Contact Area : 6 $\mu$ "min. Gold over 50  $\mu$ "min. Nickel**

**RJ Joint Contact : SPCC, Thickness=0.30mm**

**Finish : 80 $\mu$ "min. Sn over 50  $\mu$ "min. Nickel**

**LED Joint Contact : SPCC, Thickness=0.50mm**

**Finish : 80 $\mu$ "min. Sn over 50  $\mu$ "min. Nickel**

##### B. Plastic Part :

**(1) Set Housing : Thermoplastic, LCP, Black**

**UL FILE NO. : E106764**

**Manufacturer : POLYPLASTICS CO LTD.**

**Grade : E130i(d)(e)**

**Flame Class : UL 94V-0**

**(2) Insert : Thermoplastic, LCP, Black**

**UL FILE NO. : E106764**

**Manufacturer : POLYPLASTICS CO LTD.**

**Grade : E130i(d)(e)**

**Flame Class : UL 94V-0**

**(3) Spacer : Thermoplastic, LCP, Black**

**UL FILE NO. : E106764**

**Manufacturer : POLYPLASTICS CO LTD.**

**Grade : E130i(d)(e)**

**Flame Class : UL 94V-0**

## MODEL NO. : TJL-009LA1

### C. Shield Material :

Cartridge  $t=0.25\pm 0.05\text{mm}$

10  $\mu$ ”-20  $\mu$ ” Thick Nickel over Brass

### D. LED Lamp :

(a) Lens Color: Transparent with color

(b) Emitted Color: Green & Yellow

(c) Viewing Angle: 60°

(d) Dominant Wavelength: Green 570nm ; Yellow 585nm

(e) Forward Current / Reverse Voltage : Green 30 mA /(5V) ; Yellow 20 mA /(5V)

(f) Material : Green (GaP/GaP) ; Yellow (GaAsP/GaP)

### Durability :

(1)1000 cycles with no function damage for RJ-45 . Abnormalities shall be present after the test.

(2)Low Level Contact Resistance :  $\Delta R=30\text{m}\Omega$  maximum (final)

(3)The sample should be mounted in the tester and fully mated and unmated 500 times per hour at the rate of 25mm/min.EIA-364-09C.

### RJ PLUG SPECIFICATION :

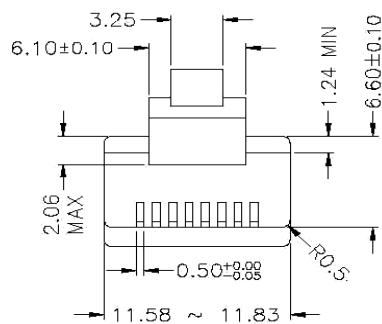

\* There must be no damage to housing or locking latch. There must be no nicks or cuts in cable.

\* Durability : 750 cycles generally

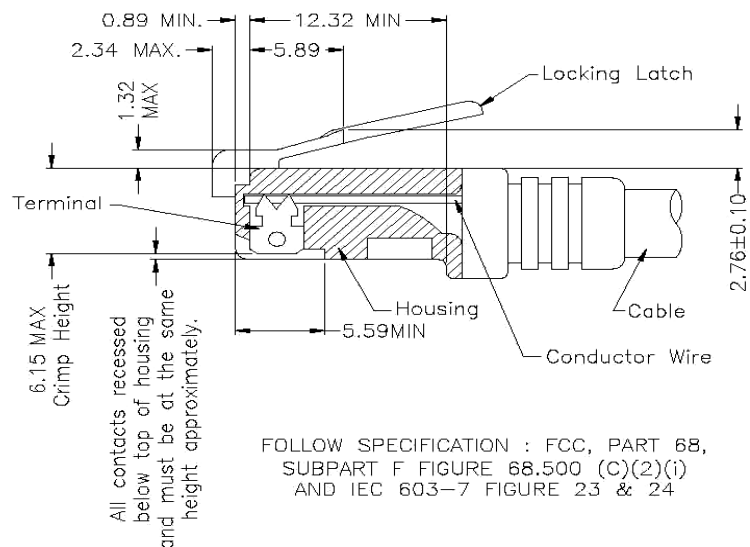

FOLLOW SPECIFICATION : FCC, PART 68,  
SUBPART F FIGURE 68.500 (C)(2)(i)  
AND IEC 603-7 FIGURE 23 & 24

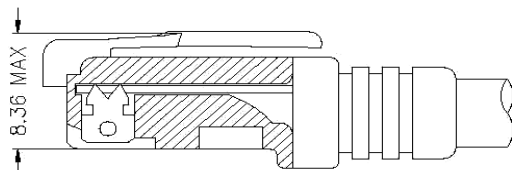

STANDARD MODULAR PLUG ASSEMBLY

FOLLOW SPECIFICATION : FCC, PART 68, SUBPART F  
FIGURE 68.500 (C)(2)(ii)

## Model NO.: TJL-009LA1

1. Unit weight :5.7 grams
2. package : 100 pcs / tray / 0.61 kgms
3. Carton : 1000 pcs / 10 layers of tray
4. Gross weight : 6.6455 kgms

### Package drawing:

